

LEPCOS (North-West Laboratory)

http://ferrite.ru Tel/fax +7-812-369-11-54

St-Petesburg, Russia

REVISIONS

REV	SYM	DRAFTER	CHECKER	DATE
△		T.S.LII	W.H.HSU	11/05/04
△				
△				

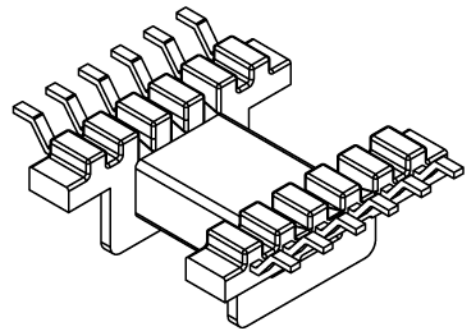
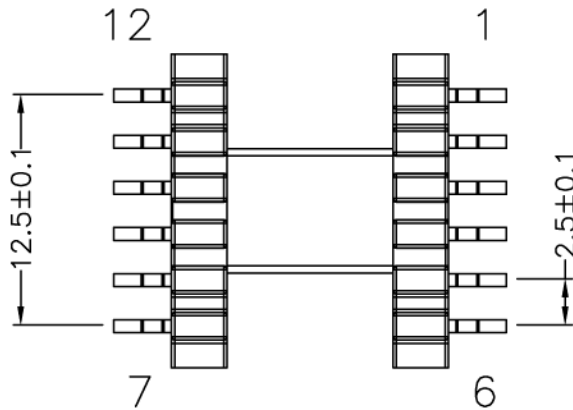
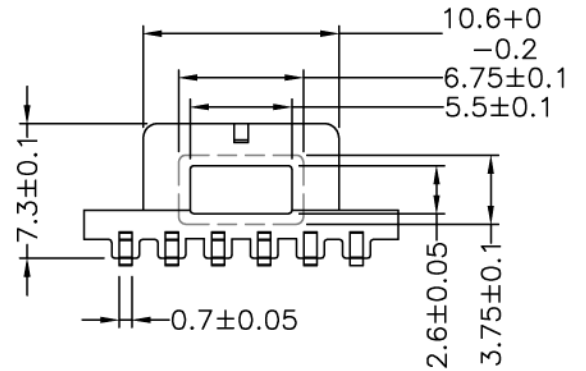
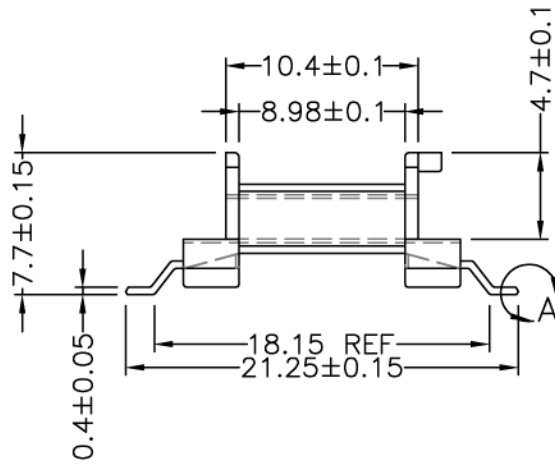
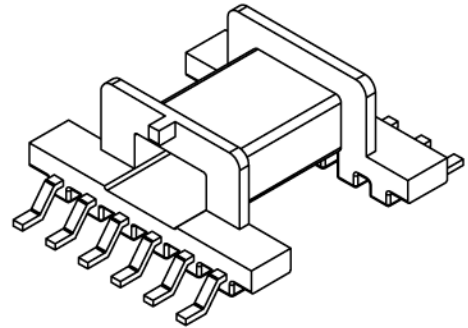
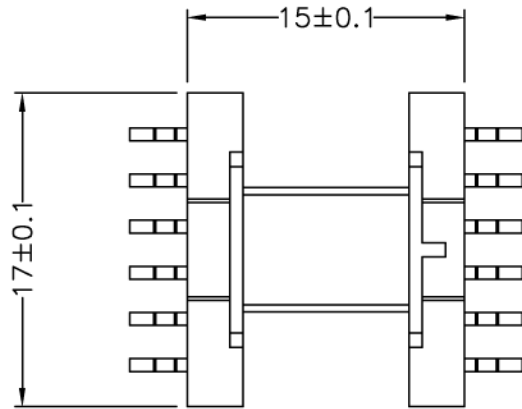

PART NO. EFD15-12P-GW-2.5-D-1

DWG NO.	MATERIAL (BOBBIN)	MATERIAL (TERMINAL)	TERMINAL (PLATING)	PIN ALOCATION	BUYER 'S PART NO.
TBI-107-03041.103	PM-9630	P.B	Sn	ALL PIN	

TOLERANCE : X ±0.15 .XX ±0.10 .XXX ±0.05 UNIT : m/m SCALE 3:1

Finish: 1. Immersion gold on terminal : Thickness gold 0.075 μm (3 μ inches) min, Base nickel 0.625 μm (25 μ inches) min.
 2. Immersion Sn on terminal : Terminal: Sn plating, 100, 5 μm (200 μ inches) min , Base nickel 0.625 μm (25 μ inches) min.
 3. Coplanarity deviation: 0.10 mm (0.004 inches) max.

REV 1