

LEPCOS (North-West Laboratory)

http://ferrite.ru Tel/fax +7-812-369-11-54

REVISIONS

REV	SYM	DRAFTER	CHECKER	DATE
①		YAN.TANG	G.F.YANG	11/05/09
②		YAN.TANG	G.F.YANG	01/06/10
③				

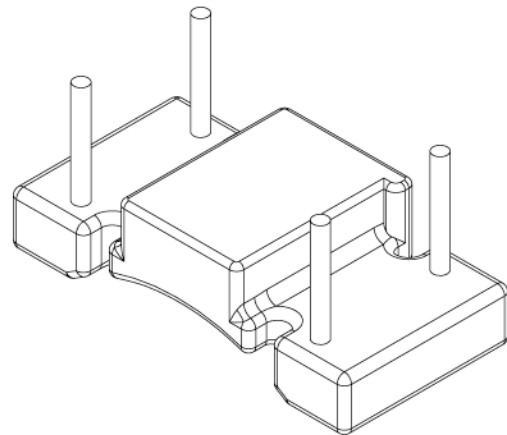
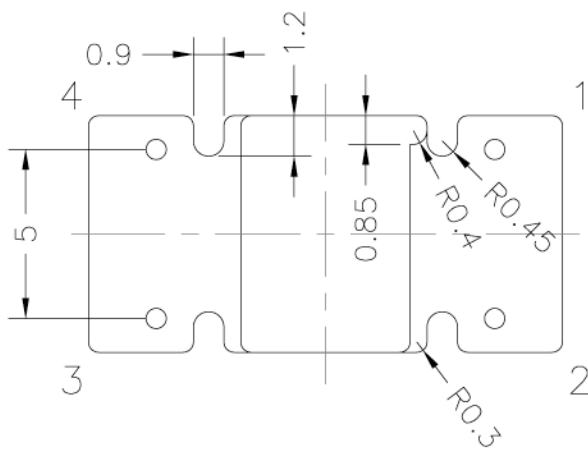
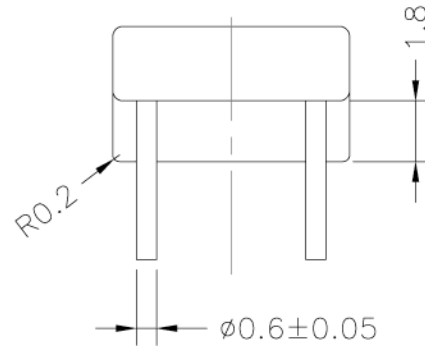
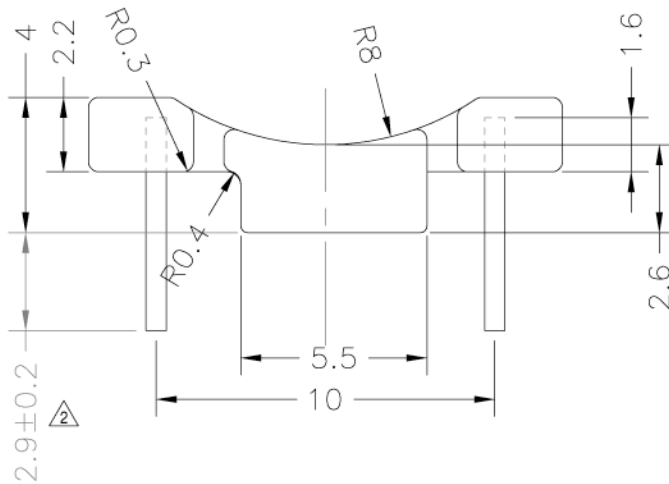
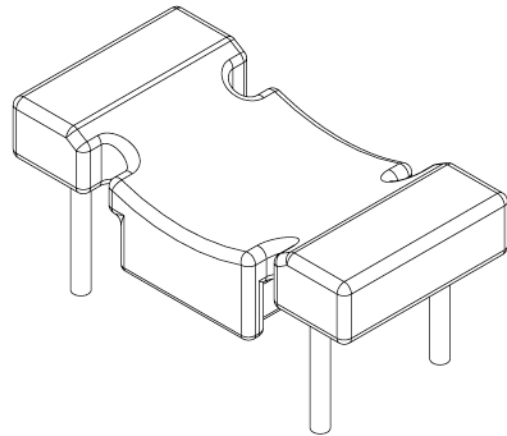
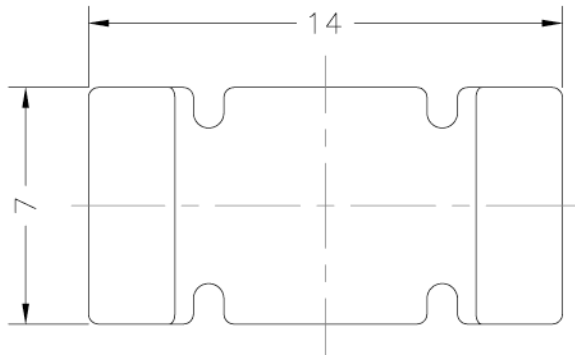

DWG NO. B14X7-4P-TH-5.0-D-12

PART NO.	MATERIAL (BOBBIN)	MATERIAL (TERMINAL)	TERMINAL (PLATING)	PIN ALLOCATION	NOTE
----------	-------------------	---------------------	--------------------	----------------	------

TBI-220-16041.1206

PM-9820

CP WIRE

Sn

ALL PIN

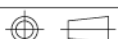

TOLERANCE: ± 0.2

UNIT : m / m

SCALE 1 : 1

Finish: 1. PB wire Immersion Sn on terminal : Thickness:Sn plating,100,5 μ m (200 μ inches) min,Base nickel 0.625 μ m (25 μ inches) min.
 2. CP wire Immersion Sn on terminal : Thickness:Sn plating,100,5 μ m (200 μ inches) min.
 3. Coplanarity deviation: 0.10 mm (0.004 inches) max.

REV

2