

LEPCOS (North-West Laboratory)
<http://ferrite.ru> Tel/fax +7-812-369-11-54

REVISIONS				
REV	SYM	DRAFTER	CHECKER	DATE
②		X.H.GU	G.F.YANG	10/06/09
③		YAN.TANG	G.F.YANG	11/11/09
④		YAN.TANG	G.F.YANG	11/20/09

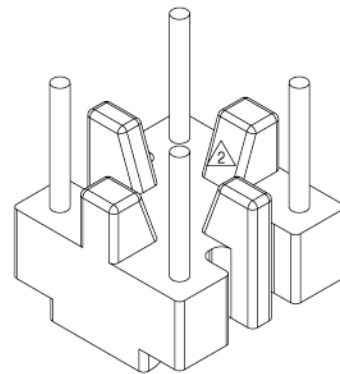
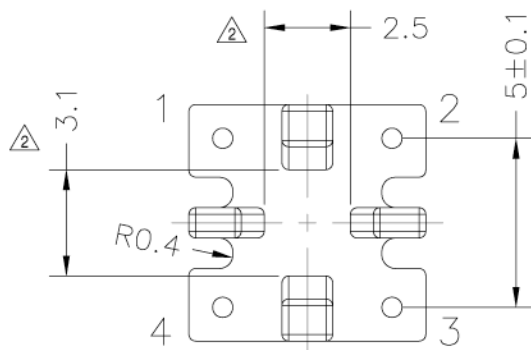
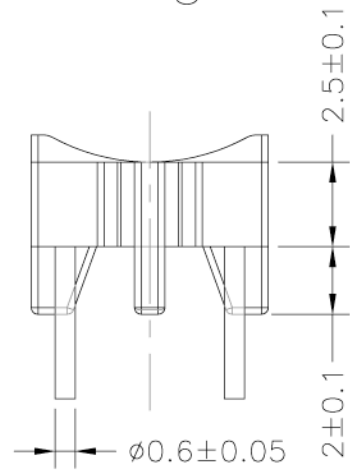
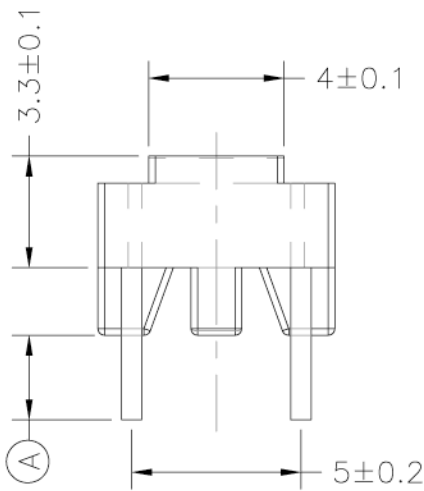
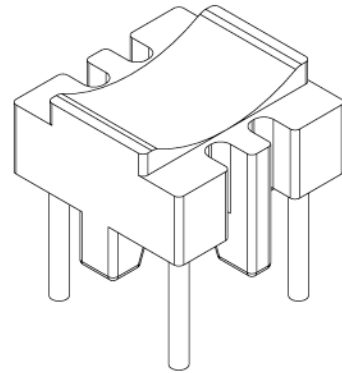
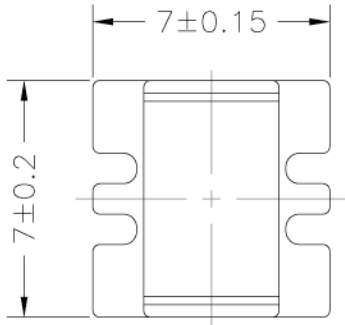

DWG NO. B7X7-4P-TH-5.0-B-12

PART NO.	MATERIAL (BOBBIN)	MATERIAL (TERMINAL)	TERMINAL (PLATING)	PIN ALLOCATION	NOTE
----------	-------------------	---------------------	--------------------	----------------	------

TBI-220-16021.1206	PM-9820	CP WIRE	Sn	ALL PIN (A)=2.5±0.3	
--------------------	---------	---------	----	---------------------	--

TBI-220-16021.1216	PM-9820	CP WIRE	Sn	ALL PIN (A)=3.5±0.2 ④	
--------------------	---------	---------	----	-----------------------	--

③ TBI-220-16021.1226	PM-9820	CP WIRE	Sn	ALL PIN (A)=5.0±0.5	
----------------------	---------	---------	----	---------------------	--

④ TBI-220-16021.1236	PM-9820	CP WIRE	Sn	ALL PIN (A)=2.7±0.2	
----------------------	---------	---------	----	---------------------	--

TOLERANCE: X±0.15 .XX±0.10 .XXX±0.05 UNIT : m / m SCALE 1 : 1

Finish: 1. PB wire Immersion Sn on terminal : Thickness:Sn plating,100,5 μm (200 μ inches) min,Base nickel 0.625 μm (25 μ inches) min.
 2. CP wire Immersion Sn on terminal : Thickness:Sn plating,100,5 μm (200 μ inches) min.
 3. Coplanarity deviation: 0.10 mm (0.004 inches) max.

REV 4