

LEPCOS (North-West Laboratory)

http://ferrite.ru Tel/fax +7-812-369-11-54

REVISIONS

REV	SYM	DRAFTER	CHECKER	DATE
1		X.H.GU	G.F.YANG	07/28/09
2		S.Y.TANG	G.F.YANG	08/07/09
3				

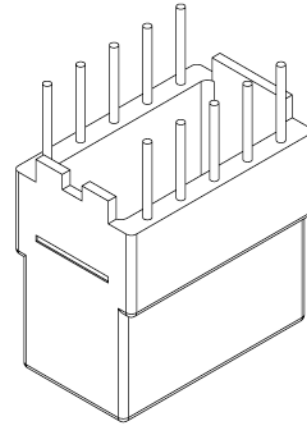
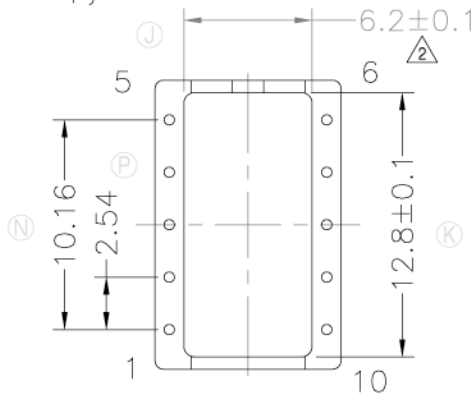
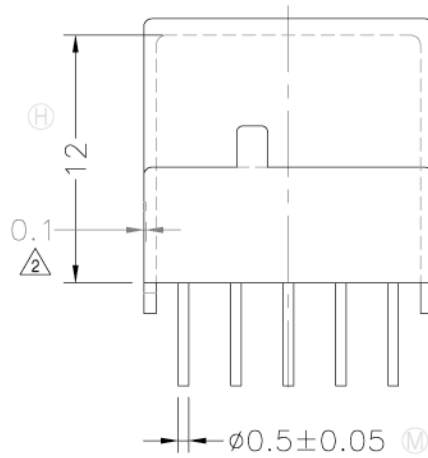
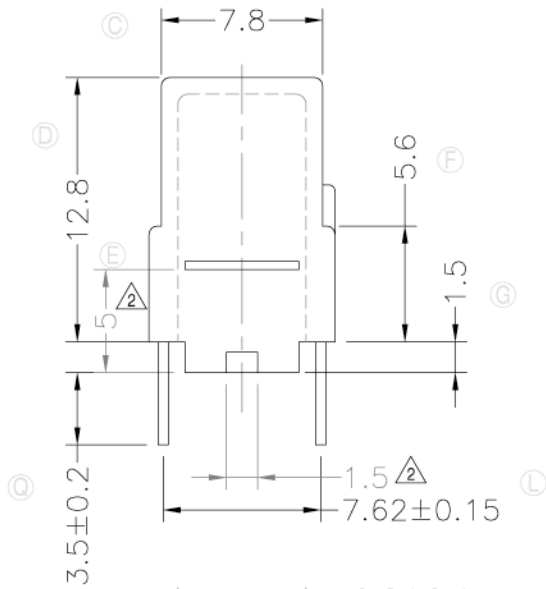
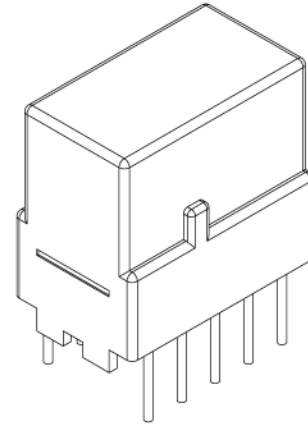
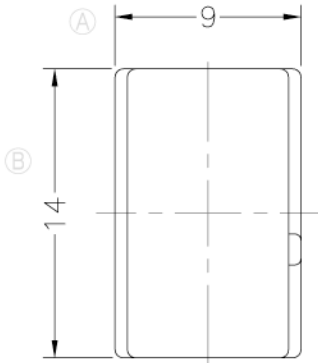

NOTE: 拉力要求 1.0Kg MIN ;

DWG NO.	H1409-10P-TH-2.54-B-12				
PART NO.	MATERIAL (BOBBIN)	MATERIAL (TERMINAL)	TERMINAL (PLATING)	PIN ALLOCATION	NOTE
TBI-218-12021.1206	PM-9820	CP WIRE	Sn	ALL PIN	
TBI-218-12021.1216	PM-9820	CP WIRE	Sn	CUT PIN #3,4,7,8	
TOLERANCE: 0<L≤4:±0.1 4<L≤16:±0.2 16<L≤63:±0.3			UNIT : m / m		SCALE 1 : 1

Finish: 1. PB wire Immersion Sn on terminal : Thickness:Sn plating,100,5 μm (200 μ inches) min,Base nickel 0.625 μm (25 μ inches) min.
 2. CP wire Immersion Sn on terminal : Thickness:Sn plating,100,5 μm (200 μ inches) min.
 3. Coplanarity deviation: 0.10 mm (0.004 inches) max.

REV 2