

# LEPCOS (North-West Laboratory)

http://ferrite.ru Tel/fax +7-812-369-11-54

## REVISIONS

REV	SYM	DRAFTER	CHECKER	DATE
△3		S.M.SHIH	S.M.SHIH	06/16/06
△4		S.M.SHIH	S.M.SHIH	07/24/06
△5		Y.G.HSU	S.M.SHIH	02/05/07

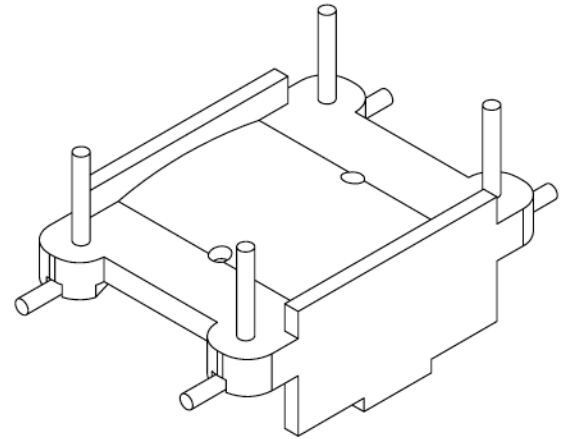
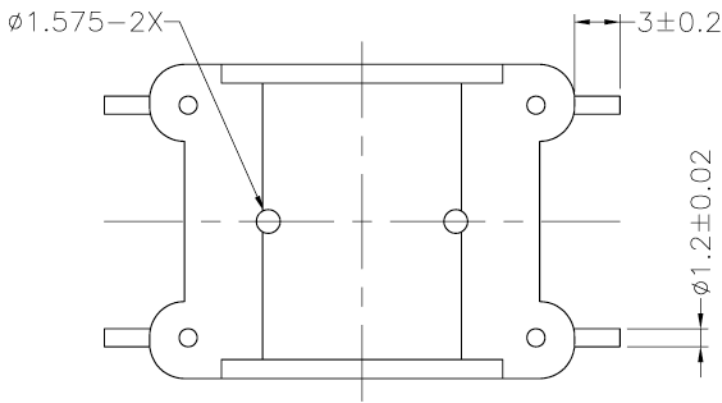
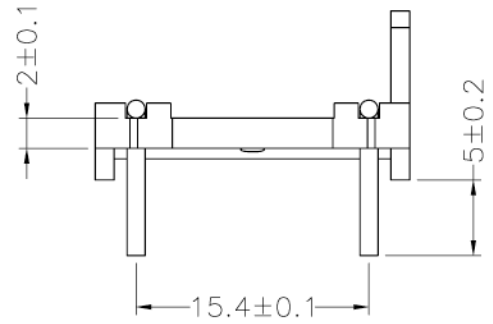
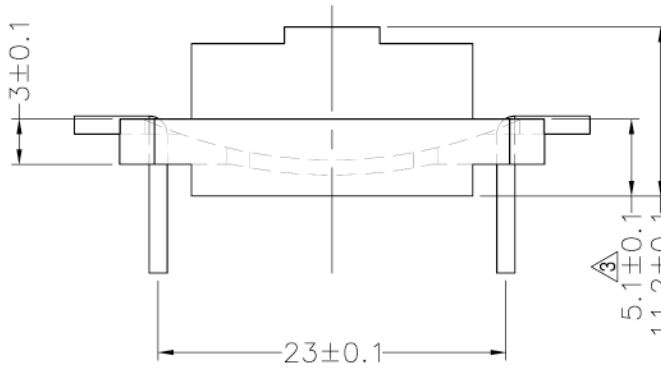
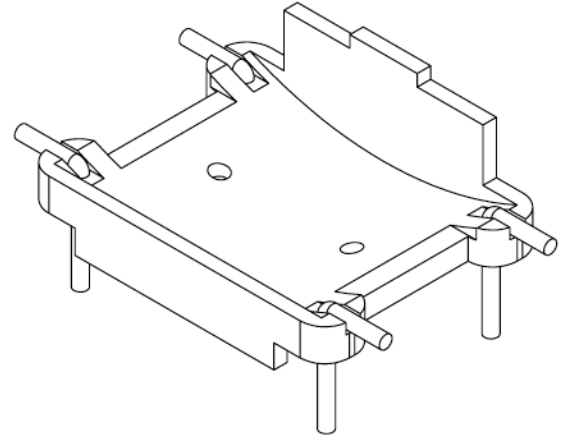
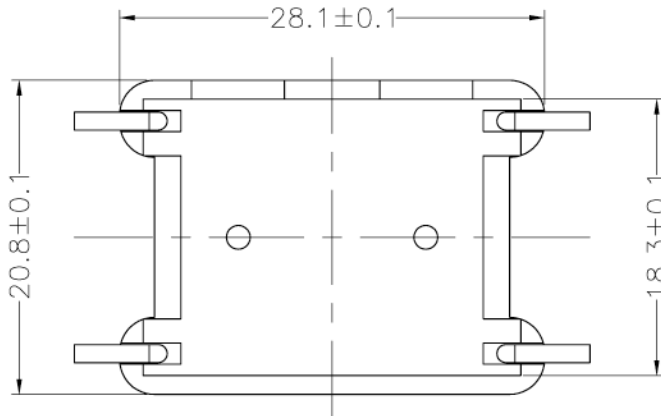

DWG NO. HEA1031-4P-THL-15.4-A-7

PART NO.	MATERIAL (BOBBIN)	MATERIAL (TERMINAL)	TERMINAL (PLATING)	PIN ALLOCATION	NOTE
TBI-220-16011.706	FR530 (BK)	C.P WIRE	Sn	ALL PIN	
TBI-220-16011.716	FR530 (BK)	NA	NA	NO PIN	
TOLERANCE: .X±0.15 .XX±0.10 .XXX±0.05				UNIT : m / m	SCALE 2 : 1

Finish: 1. Pb wire Immersion Sn on terminal : Thickness:Sn plating,100,5  $\mu$ m (200  $\mu$  inches) min,Base nickel 0.625  $\mu$ m (25  $\mu$  inches) min.  
 2. CP wire Immersion Sn on terminal : Thickness:Sn plating,100,5  $\mu$ m (200  $\mu$  inches) min.  
 3. Coplanarity deviation: 0.10 mm (0.004 inches) max.

REV 5