

LEPCOS (North-West Laboratory)

http://ferrite.ru Tel/fax +7-812-369-11-54

REVISIONS

REV	SYM	DRAFTER	CHECKER	DATE
1		X.H.GU	G.F.YANG	09/07/10
2		X.H.GU	G.F.YANG	10/29/10
3				

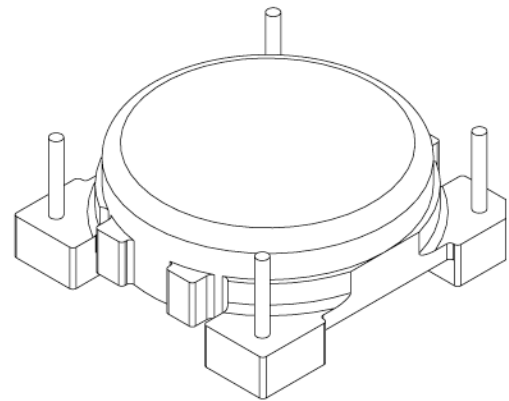
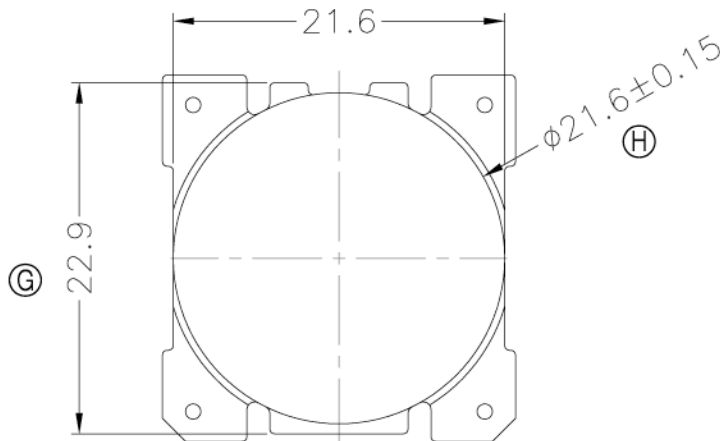
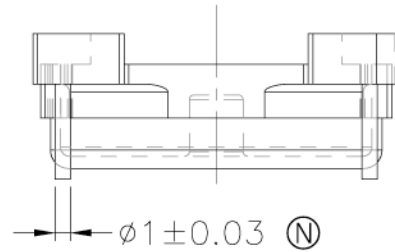
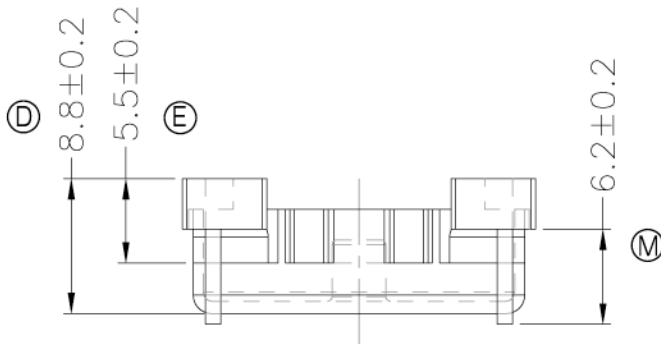
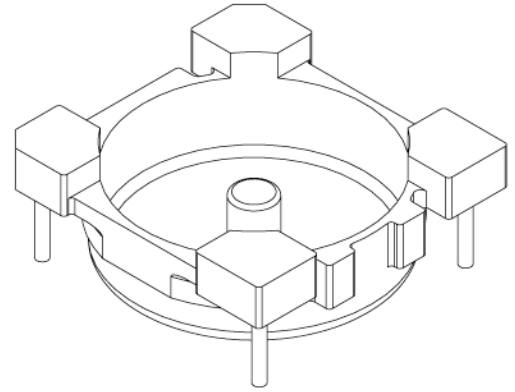
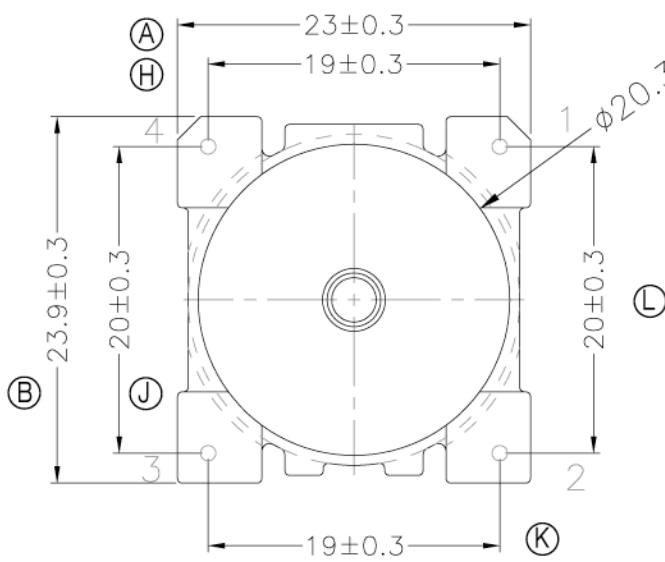

DWG NO. OR18X6-12C-BASE-B6-12

PART NO.	MATERIAL (BOBBIN)	MATERIAL (TERMINAL)	TERMINAL (PLATING)	PIN ALLOCATION	NOTE
TBI-220-16261.1206	PM-9820	CP WIRE	Sn	ALL PIN	S
TBI-220-16261.1216	PM-9820	CP WIRE	Sn	CUT PIN #4	H

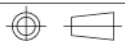

TOLERANCE: ±0.2

UNIT : m / m

SCALE 1 : 1

Finish: 1. PB wire Immersion Sn on terminal : Thickness:Sn plating,100,5 μm (200 μ inches) min,Base nickel 0.625 μm (25 μ inches) min.
 2. CP wire Immersion Sn on terminal : Thickness:Sn plating,100,5 μm (200 μ inches) min.
 3. Coplanarity deviation: 0.10 mm (0.004 inches) max.

REV 2