



ISO9001-2008
Certificate No:02411Q20838R2M

CAREFUL環境關聯物質管控標準: Cd<5ppm; Pb<50ppm; Hg:ND; Cr6+:ND

Defer to: **SONY/SS-00259** ; SAMSUNG/OQA-2049 ; **MICROSOFT/H00594** ; FOXCONN/EPI12 ; **HP/HX-00011-00...**

承 認 書

SPECIFICATION FOR APPROVAL

客户名稱 CUSTOMER	LEPCOSLTD
品名規格 DESCRIPTION	F9 SCRC 90 B
客户料號 CUS. P/N	
提出日期 DATE	Dec.14.2022.
編 號 SERIAL NO.	KF 22121433474

出 圖 DRAWING			承 認 CUSTOMER APPROVE	
發行 MADE	復 核 CHECKED	確 認 APPROVED		
DATE: 2022年12月14日				



科峰集團

CAREFUL GROUP

www.careful.cn

sales@careful.cn
info@careful.cn

湖州科峰磁業有限公司
HuZhou Careful Magnetism Co.,Ltd.

浙江省湖州市含山工業區 313014
Hanshan Industry Zone Huzhou Zhejiang

TEL: 00 86 - 572 - 367 0006 / 367 2766
TEL: 00 86 - 572 - 367 0006 / 367 2766

FAX: 00 86 - 572 - 367 0025
FAX: 00 86 - 572 - 367 0025

嘉興科峰磁電有限公司
JiaXing Careful Magnetism & Electron Co.,Ltd.



浙江省嘉興市河山工業區 314512
Heshan Industry Zone Jiaying Zhejiang

TEL: 00 86 - 573 - 8867 1616 / 8867 0988
TEL: 00 86 - 573 - 8867 1616 / 8867 0988

FAX: 00 86 - 573 - 8867 1515
FAX: 00 86 - 573 - 8867 1515

承認書

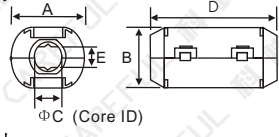
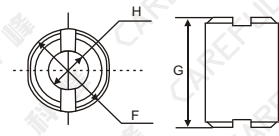
SPECIFICATION FOR APPROVAL

客戶名稱 CUSTOMER	LEPCOSLTD	日期 DATE	2022.12.14.
規格 ITEM	F9 SCRC 90 B	編號 SERIAL NO.	KF 22121433474
1.1. 形狀尺寸(單位/毫米): SHAPE & DIMENSION(unit/mm): 1.2. 實物圖: The Sample::		A	19.5 ± 1.0 mm
外殼尺寸: 		B	18.0 ± 1.0 mm
磁芯尺寸: 		C	9.0 ± 0.8 mm
		D	35.0 ± 1.0 mm
		E	5.5 ± 1.0 mm
		F	16 ± 0.5 mm
		G	28 ± 0.7 mm
		H	9 ± 0.4 mm

2. 電氣性能檢測項目: ELECTRICAL REQUIREMENTS:				測試儀器 TEST INSTRUMENTS			
<input type="checkbox"/> L		TEST FREQ		1. Q-METER: ○ HP 4342A ○ MQ-172			
<input type="checkbox"/> Q		TEST FREQ		2. L.C.R. METER: ○ HP 4284A			
<input checked="" type="checkbox"/> Z	Z1= 60Ω MIN	KHZ	25 MHZ	Z2=150Ω MIN	KHZ	100 MHZ	3. IMPEDANCE ANALYZER: ○ HP 4396B ○ HP 4191A ØE4991A ØAgilent 16194A-TESTFIXTURE
	Z3=	KHZ	MHZ	Z4=	KHZ	MHZ	4. L-METER: ○ TH 2817A
溫度 TEMP	℃	濕度 HUMIDITY	%	5. DIGITAL MINI-OHMMETER: ○ VP2941A			
線組 WINDING	Φ0.5x0.5TSx100L(mm)						

3. 外觀標準: 依下表對照檢索:
THE LIMIT OF BREAKAGE: CHECKED BELOW:

OD (mm)	0~5	5.1~10	10.1~15	15.1~20	20.1~25	25.1~30	30.1~35	35以上
缺陷面积 Defect area (mm ²)	≦1	≦2	≦3	≦4	≦5	≦6	≦7	≦8
缺陷个数 Number of defects (≦)	1	2	3	3	3	3	2	2



4. 材質特性 MATERIAL CHARACTERISTICS

材料牌號 Material	初始磁導率 Initial Permeability	比損耗因子 Relative Loss Factor	比溫度系數 Relative Temperature Coefficient	飽和磁通密度 Saturation Magnetic Flux Density	剩磁 Remanence	矯頑力 Coercivity	居裏溫度 Curie Temperature	電阻率 Electrical Resistivity	密度 Density
Unit symbol	μ _i ±20%	Tan δ / μ _i ×10 ⁻⁶	α μ _i γ ×10 ⁻⁶	B _s (MT)	Br (MT)	HC (A/m)	T _c (°C)	ρ (Ω · m)	d g/cm ³
F9	850	16 (0.1MHz)	5 - 10	280(1600A/m)	200	20	>130	>10 ⁵	4.6

A	首版First Edition	2022-12-14	Rosie
版本Rev.	變更內容說明Description of Change	日期Date	姓名Name

檢驗數據

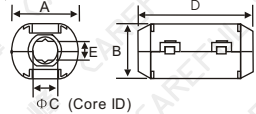
INSPECTION DATA

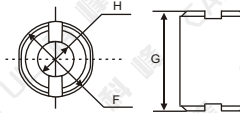
客戶名稱 CUSTOMER	LEPCOSLTD		日期 DATE	2022.12.14.	數量 QUANTITY	5PCS
編號 SERIAL NO.	KF 22121433474		1.1形狀尺寸(單位:毫米): SHAPE & DIMENSION(unit:mm):		實物圖: The Sample:::	
規格 ITEM	F9 SCRC 90 B		外殼尺寸: 			
繞組 WINDING	Φ0.5x0.5TSx100L(mm)		磁芯尺寸: 			
測試頻率 TEST FREQ	Z1=	KHZ 25 MHZ	Z2=	KHZ 100 MHZ		
	Z3=	KHZ MHZ	Z4=	KHZ MHZ		
溫度 TEMP	°C	濕度 HUMIDITY				

項目 TEST ITEM	電氣性能 ELECTRIC CHARACTERISTICS				尺寸(單位:毫米) DIMENSION(unit:mm)							
	Z1(Ω)	Z2(Ω)	Z3(Ω)	Z4(Ω)	A	B	C	D	E	F	G	H
	60	150			19.5	18.0	9.0	35.0	5.5	16	28	9
+	/	/			1.0	1.0	0.8	1.0	1.0	0.5	0.7	0.4
-	0	0			1.0	1.0	0.8	1.0	1.0	0.5	0.7	0.4
1	86.6	170.0			19.30	18.40	8.60	35.40	5.50	15.70	27.78	8.68
2	87.7	169.5			19.40	18.30	8.80	35.50	5.60	15.60	27.66	8.66
3	87.2	169.9			19.39	18.31	8.70	35.48	5.40	15.57	27.64	8.81
4	86.6	170.1			19.37	18.33	8.63	35.46	5.45	15.69	27.65	8.74
5	87.6	170.6			19.35	18.35	8.72	35.44	5.52	15.62	27.69	8.69
6	87.3	170.2			19.33	18.37	8.69	35.42	5.48	15.63	27.66	8.75
7	87.8	169.0			19.38	18.39	8.71	35.47	5.53	15.64	27.74	8.71
8	86.2	169.4			19.36	18.32	8.68	35.49	5.47	15.68	27.71	8.78
9	86.9	169.5			19.34	18.34	8.64	35.42	5.49	15.59	27.73	8.77
10	87.5	170.3			19.32	18.36	8.67	35.48	5.51	15.67	27.75	9.73
\bar{X}	87.14	169.85			19.35	18.35	8.68	35.45	5.49	15.63	27.70	8.73
Y/N	Y	Y			Y	Y	Y	Y	Y	Y	Y	Y

測試儀器:
TEST INSTRUMENTS:

E4991A+16194A

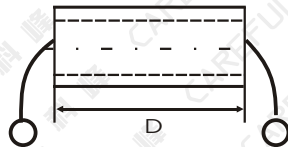

檢驗 INSPECTED	復核 CHECKED	確認 APPROVED
汪建琴		

A	首版First Edition	2022-12-14	Rosie
版本Rev.	變更內容說明Description of Change	日期Date	姓名Name

阻抗 - 頻率曲線

IMPEDANCE V.S FREQUENCY (Z-Y)

客戶名稱 CUSTOMER	LEPCOSLTD.	日期 DATE	2022.12.14.
規格 ITEM	F9 SCRC 90 B	編號 SERIAL NO.	KF 22121433474

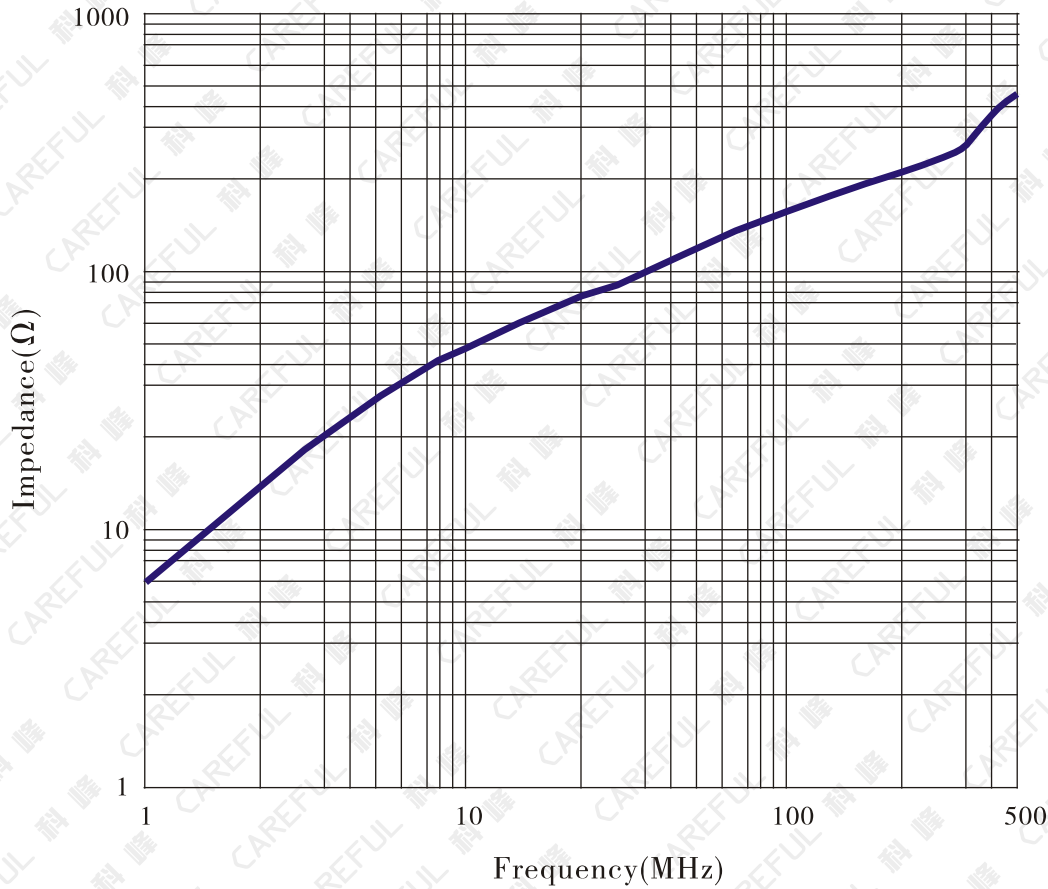

測試條件:
TESTING CONDITION:

- 測試儀器: E4991A+16194A
Testing Equipment:
- 測試頻率區間: 1-500MHz
Testing Frequency Range:
- 測試綫組: Φ0.5x0.5TSx100L(mm)
Testing Coil Specification:

說明Note:
本承認書在客戶收到7天之內, 須簽章返回, 逾期視為默認。
The Specification Approval is required to be sent back to the supplier with customer's chop or signature on it within 4 days after receiving it, or we will take it as approved by customer automatically.

測試 TESTED	復核 CHECKED	確認 APPROVED
汪建琴	沈學泉	周紀君

A	首版First Edition	2022-12-14	Rosie
版本Rev.	變更內容說明Description of Change	日期Date	姓名Name