

LEPCOS (North-West Laboratory)

http://ferrite.ru Tel/fax +7-812-369-11-54
St-Petesburg, Russia

REVISIONS

REV	SYM	DRAFTER	CHECKER	DATE
△		T.S.LII	W.H.HSU	02/11/03
△		T.S.LII	W.H.HSU	06/02/03
△		T.S.LII	W.H.HSU	12/17/04

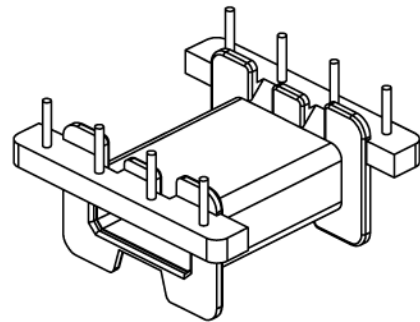
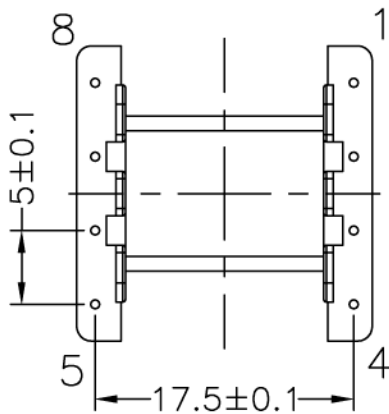
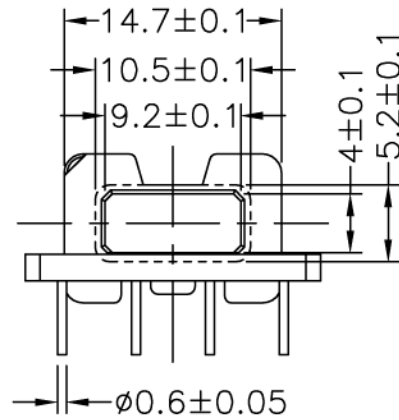
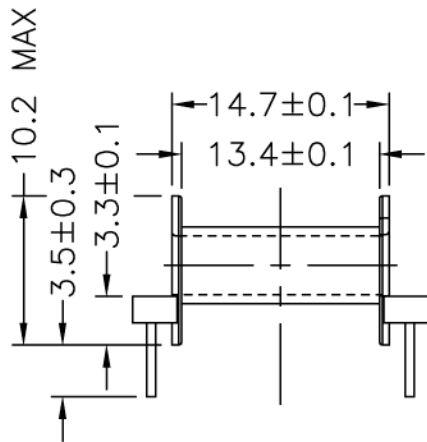
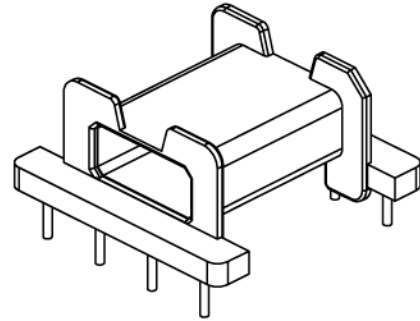
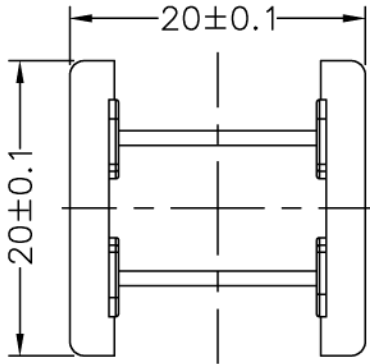

PART NO.	EFD20 Bobbin 1 sec 8 pin E-032				
DWG NO.	MATERIAL (BOBBIN)	MATERIAL (TERMINAL)	TERMINAL (PLATING)	PIN ALOCATION	BUYER 'S PART NO.
E-032	PM-9630	CP WIRE	Sn	ALL PIN	

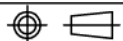

TOLERANCE: .X±0.15 .XX±0.10 .XXX±0.05

UNIT : m/m

SCALE 2 : 1

Finish: 1. Immersion gold on terminal : Thickness gold 0.075 μm (3 μ inches) min, Base nickel 0.625 μm (25 μ inches) min.
2. Immersion Sn on terminal : Terminal: Sn plating, 100, 5 μm (200 μ inches) min , Base nickel 0.625 μm (25 μ inches) min.
3. Coplanarity deviation: 0.10 mm (0.004 inches)max.

REV 4