

LEPCOS (North-West Laboratory)
 www.ferrite.ru Tel/Fax +7-812-369-11-54
 St-Petersburg, Russia

REVISIONS				
REV	SYM	DRAFTER	CHECKER	DATE
△2		H.X.DUAN	W.H.HSU	06/19/10
△3		H.X.DUAN	W.H.HSU	07/09/10
△4		X.H.GU	G.F.YANG	09/14/10

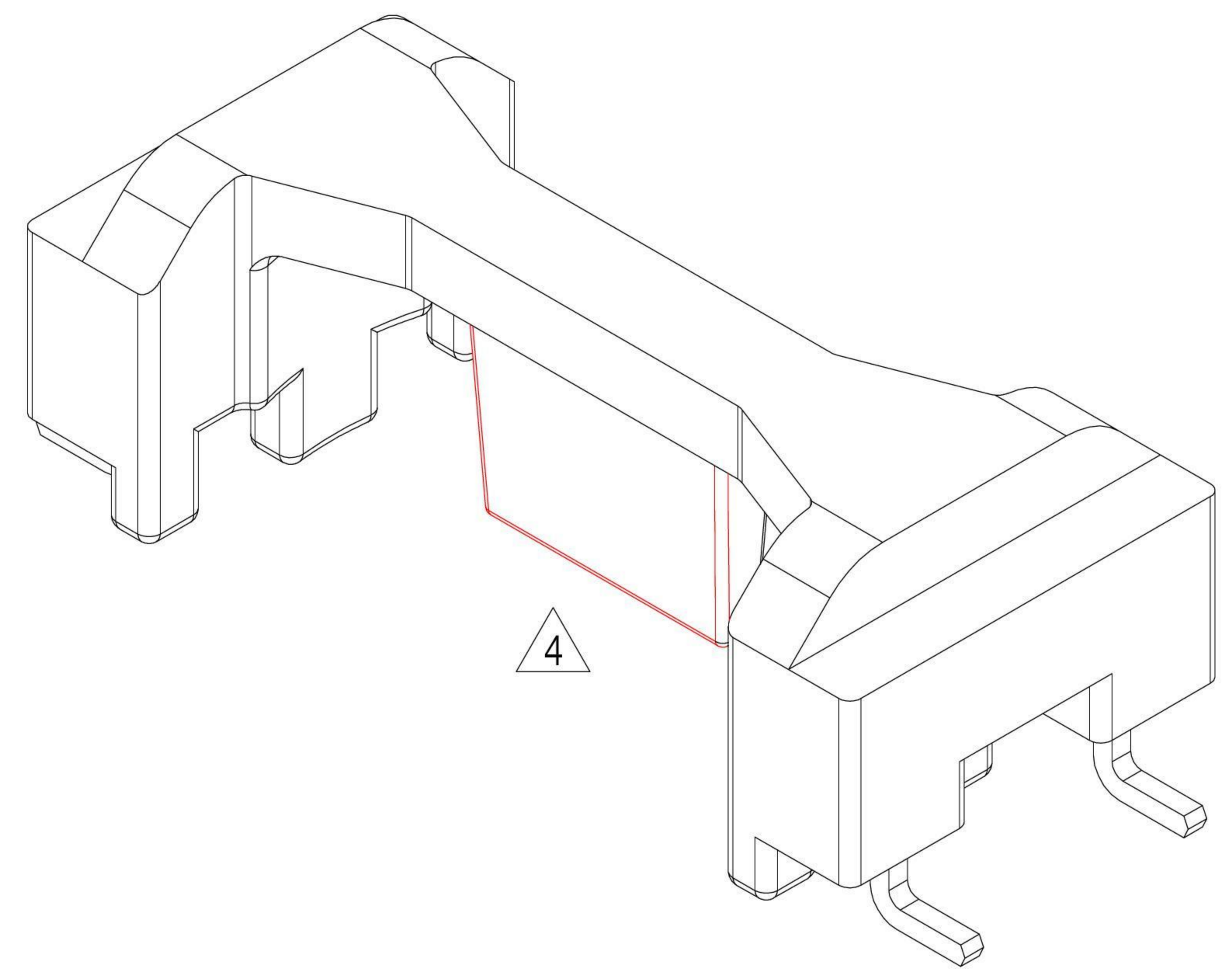
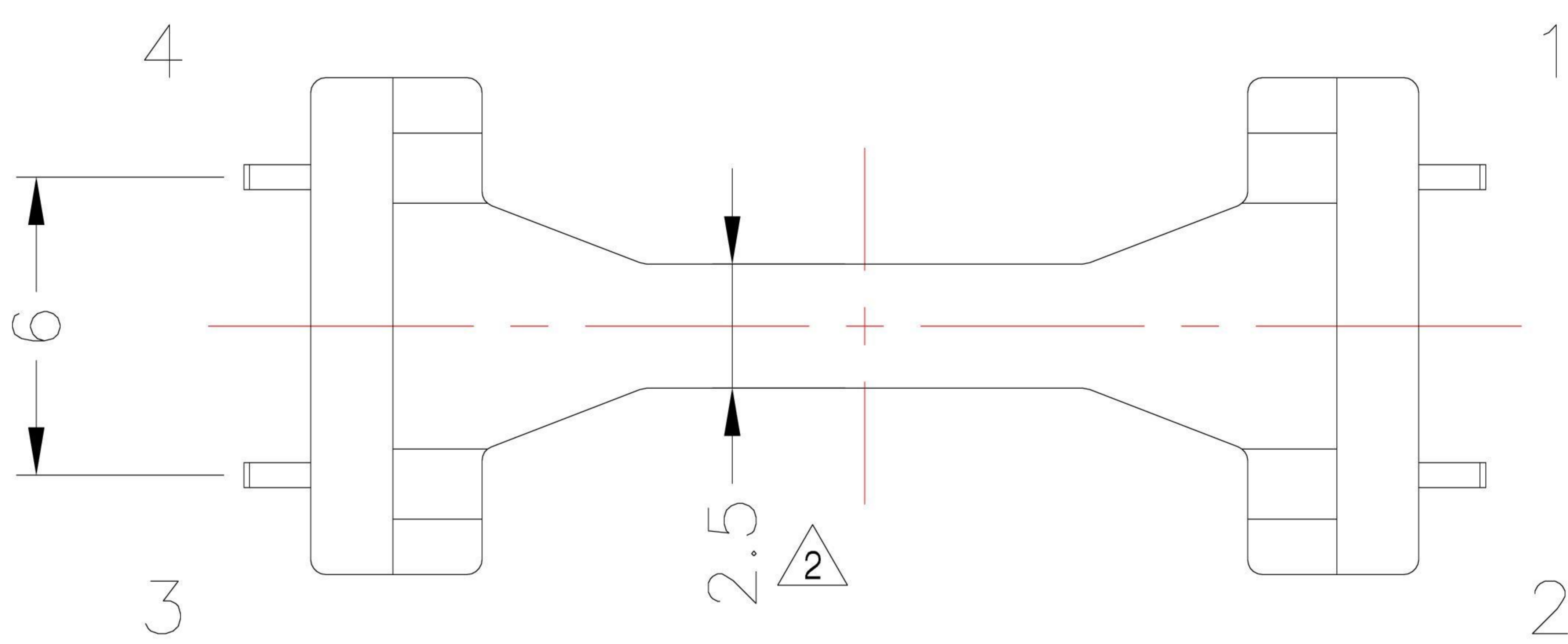
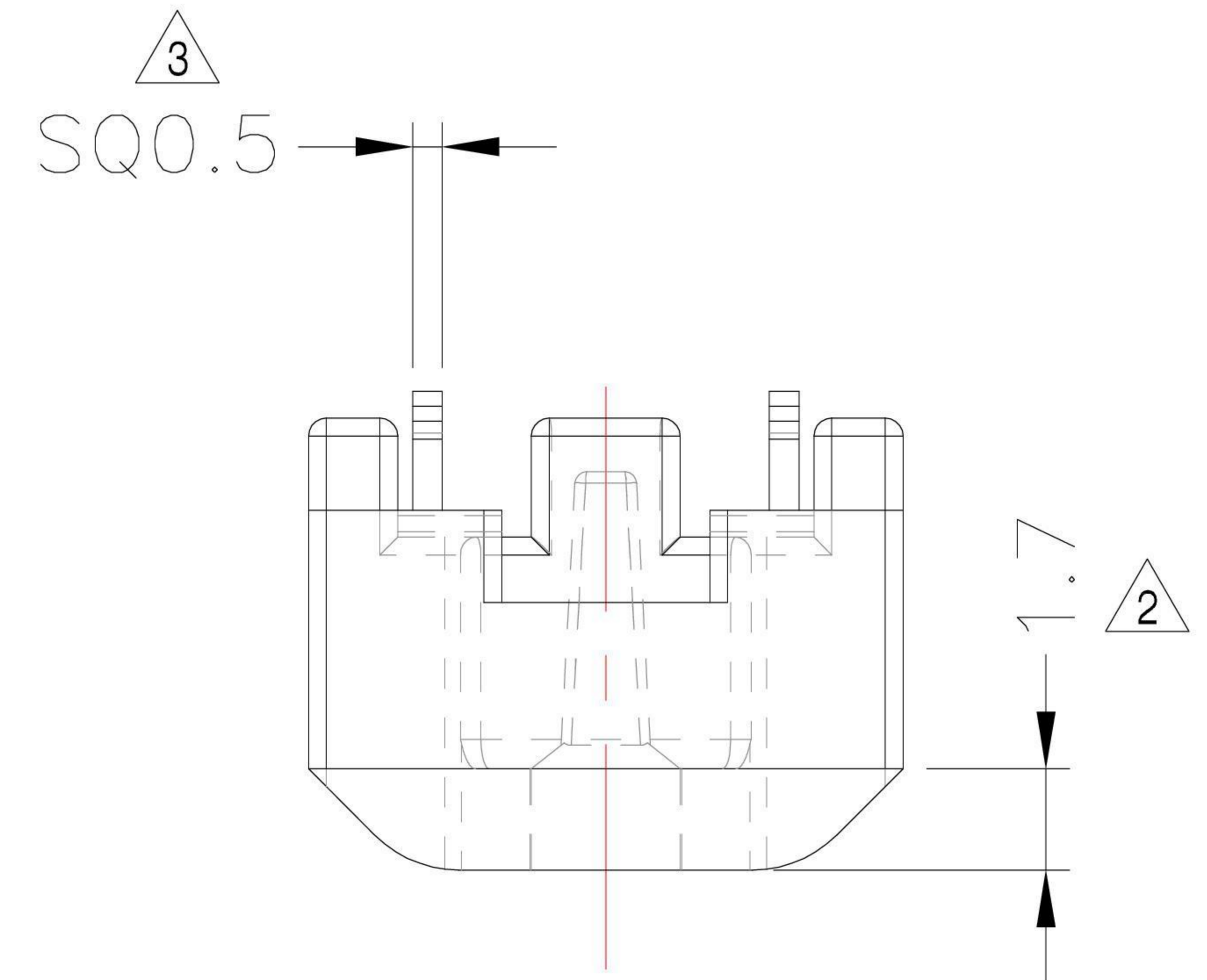
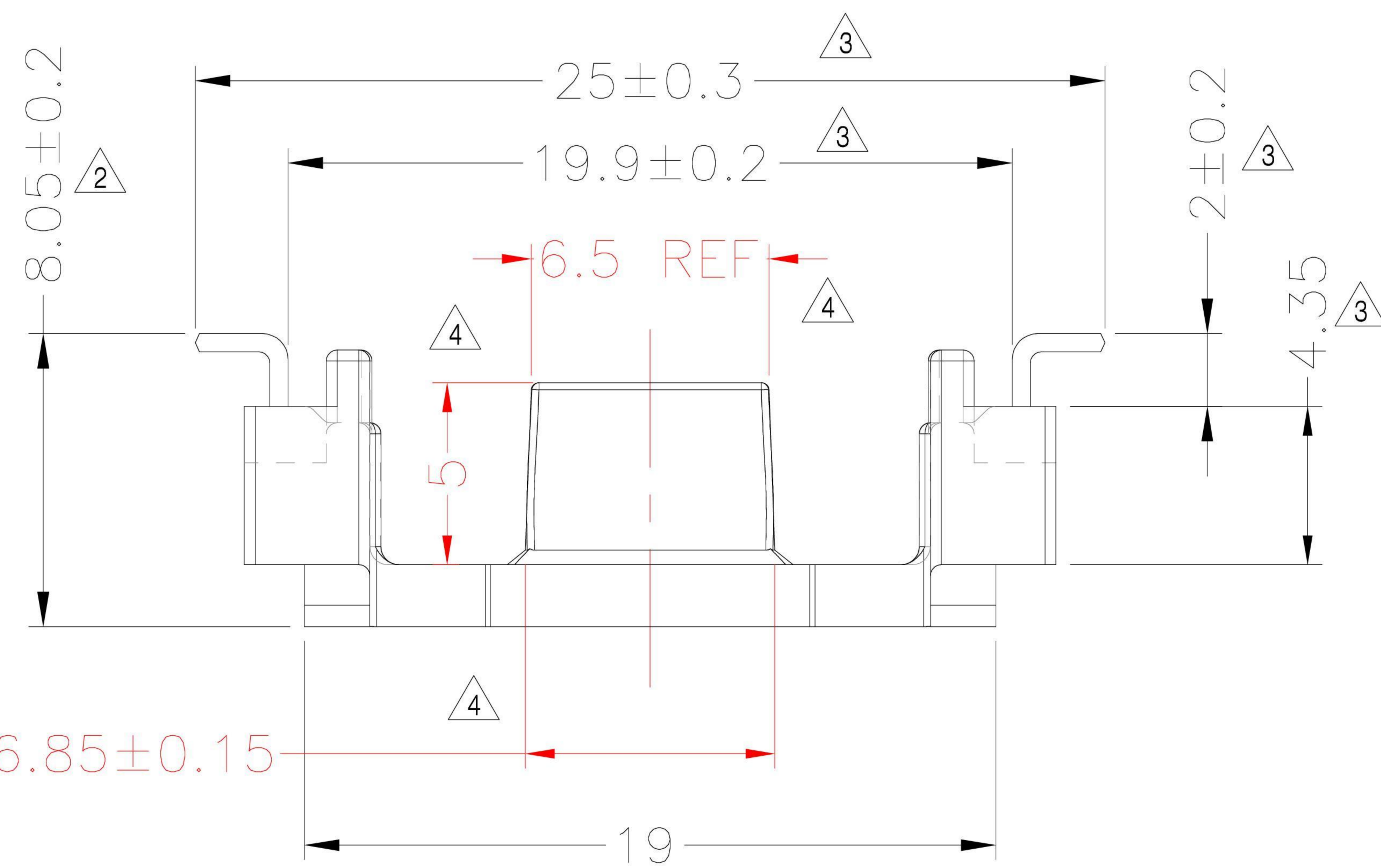
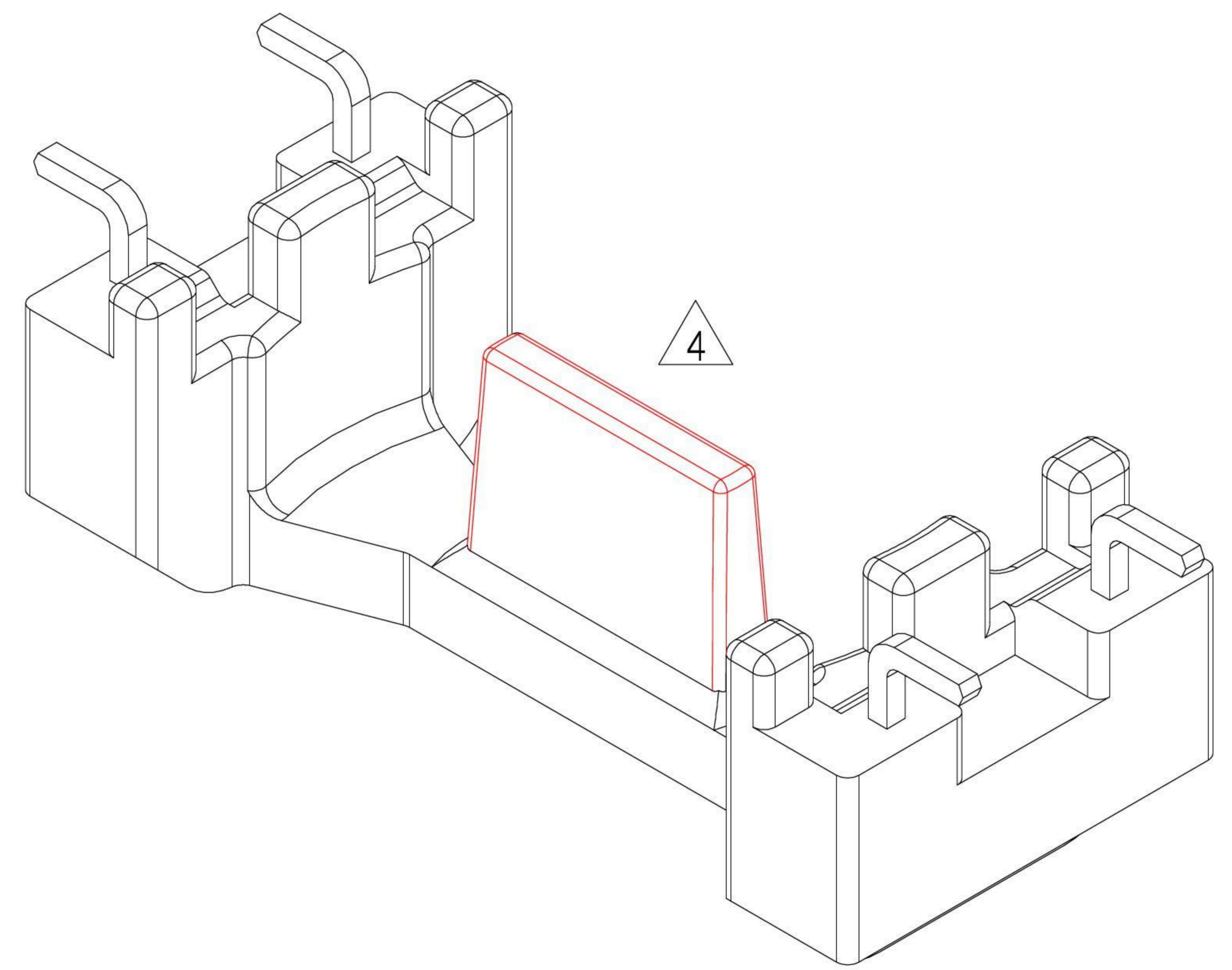
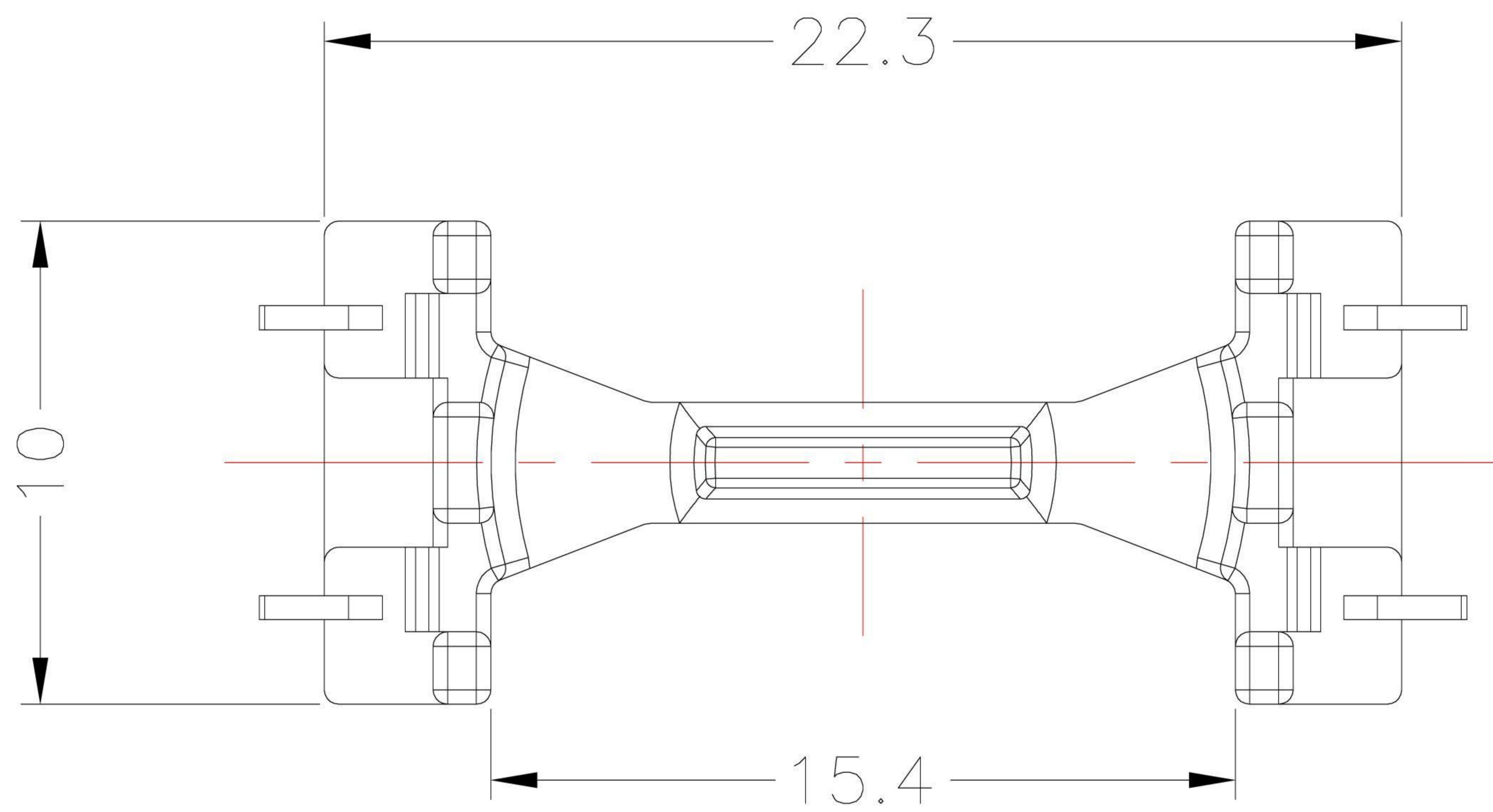

DWG NO. OR14X4-8-BASE-4P-B-12

PART NO.	MATERIAL (BOBBIN)	MATERIAL (TERMINAL)	TERMINAL (PLATING)	PIN ALLOCATION	NOTE
TBI-120-07021.1206	PM-9820(BK)	CP WIRE	Sn	ALL PIN	S
					H

TOLERANCE: 0<L<=4:±0.1 4<L<=16:±0.2 16<L<=63:±0.3 UNIT : m / m SCALE 1 : 1

Finish: 1. PB wire Immersion Sn on terminal : Thickness:Sn plating,100,5 μm (200 μ inches) min,Base nickel 0.625 μm (25 μ inches) min.
 2. CP wire Immersion Sn on terminal : Thickness:Sn plating,100,5 μm (200 μ inches) min.
 3. Coplanarity deviation: 0.10 mm (0.004 inches) max.

REV 4