



CAREFUL環境關聯物質管控標準: Cd<5ppm; Pb<50ppm; Hg:ND; Cr6+:ND

ISO9001-2008  
Certificate No:02411Q20838R2M

Defer to: **SONY/SS-00259** ; SAMSUNG/OQA-2049 ; **MICROSOFT/H00594** ; FOXCONN/EPI12 ; **HP/HX-00011-00...**

# 承 認 書

## SPECIFICATION FOR APPROVAL

客戶名稱 CUSTOMER	LEPCOSLTD
品名規格 DESCRIPTION	F9 SCRC 70 B
客戶料號 CUS. P/N	
提出日期 DATE	Dec.14.2022.
編 號 SERIAL NO.	KF 22121433473

出 圖 DRAWING			承 認 CUSTOMER APPROVE	
發行 MADE	復 核 CHECKED	確 認 APPROVED		
DATE: 2022年12月14日				



科峰集團

CAREFUL GROUP

www.careful.cn  
sales@careful.cn  
info@careful.cn

湖州科峰磁業有限公司  
HuZhou Careful Magnetism Co.,Ltd.

浙江省湖州市含山工業區 313014  
Hanshan Industry Zone Huzhou Zhejiang

TEL: 00 86 - 572 - 367 0006 / 367 2766  
TEL: 00 86 - 572 - 367 0006 / 367 2766

FAX: 00 86 - 572 - 367 0025  
FAX: 00 86 - 572 - 367 0025

嘉興科峰磁電有限公司  
JiaXing Careful Magnetism & Electron Co.,Ltd.

浙江省嘉興市河山工業區 314512  
Heshan Industry Zone Jiaxing Zhejiang

TEL: 00 86 - 573 - 8867 1616 / 8867 0988  
TEL: 00 86 - 573 - 8867 1616 / 8867 0988

FAX: 00 86 - 573 - 8867 1515  
FAX: 00 86 - 573 - 8867 1515

# 承認書

## SPECIFICATION FOR APPROVAL

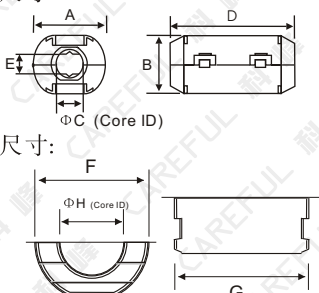
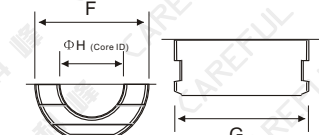
客戶名稱 CUSTOMER	LEPCOSLTD	日期 DATE	2022.12.14.
規格 ITEM	F9 SCRC 70B	編號 SERIAL NO.	KF 22121433473
1.1. 形狀尺寸(單位/毫米): SHAPE & DIMENSION(unit/mm): 1.2. 實物圖: The Sample::		A	16.5 ± 1.0 mm
外觀尺寸: 		B	14.0 ± 1.0 mm
磁芯尺寸: 		C	7.0 ± 0.8 mm
		D	30.0 ± 1.0 mm
		E	2.5 ± 1.0 mm
		F	13 ± 0.5 mm
		G	23 ± 0.6 mm
		H	7.0 ± 0.5 mm

2. 電氣性能檢測項目: ELECTRICAL REQUIREMENTS:		測試儀器 TEST INSTRUMENTS	
<input type="checkbox"/> L		TEST FREQ	KHZ MHZ
<input type="checkbox"/> Q		TEST FREQ	KHZ MHZ
<input checked="" type="checkbox"/> Z	Z1=75Ω MIN	KHZ 25MHZ	Z2=130Ω MIN
	Z3= /	KHZ MHZ	Z4= /
溫度 TEMP	℃	濕度 HUMIDITY	%
線組 WINDING	Φ0.5x0.5TSx100L(mm)		

1. Q-METER:  
○HP 4342A ○MQ-172

2. L.C.R. METER:  
○HP 4284A

3. IMPEDANCE ANALYZER:  
○HP 4396B ○HP 4191A ØE4991A  
ØAgilent 16194A-TESTFIXTURE

4. L-METER:  
○TH 2817A

5. DIGITAL MINI-OHMMETER:  
○VP2941A

3. 外觀標準: 依下表對照檢索:  
THE LIMIT OF BREAKAGE: CHECKED BELOW:

OD (mm)	0~5	5.1~10	10.1~15	15.1~20	20.1~25	25.1~30	30.1~35	35以上
缺陷面积 Defect area (mm <sup>2</sup> )	≦1	≦2	≦3	≦4	≦5	≦6	≦7	≦8
缺陷个数 Number of defects (≦)	1	2	3	3	3	3	2	2

4. 材質特性 MATERIAL CHARACTERISTICS

材料牌號 Material	初始磁導率 Initial Permeability	比損耗因子 Relative Loss Factor	比溫度係數 Relative Temperature Coefficient	飽和磁通密度 Saturation Magnetic Flux Density	剩磁 Remanence	矯頑力 Coercivity	居裏溫度 Curie Temperature	電阻率 Electrical Resistivity	密度 Density
Unit symbol	μ <sub>i</sub> ±20%	Tan δ / μ <sub>i</sub> ×10 <sup>-6</sup>	α μ <sub>i</sub> γ ×10 <sup>-6</sup>	B <sub>s</sub> (MT)	B <sub>r</sub> (MT)	HC (A/m)	T <sub>c</sub> (°C)	ρ (Ω · m)	d g/cm <sup>3</sup>
F9	850	16 (0.1MHz)	5 - 10	280(1600A/m)	200	20	>130	>10 <sup>5</sup>	4.6

A	首版First Edition	2022-12-14	Rosie
版本Rev.	變更內容說明Description of Change	日期Date	姓名Name

# 檢驗數據

## INSPECTION DATA

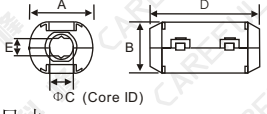
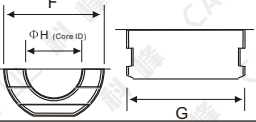
客戶名稱 CUSTOMER	LEPCOSLTD		日期 DATE	2022.12.14.	數量 QUANTITY	5PCS
編號 SERIAL NO.	KF 22121433473		形狀尺寸(單位/毫米): SHAPE & DIMENSION(unit/mm): 外殼尺寸:	實物圖: The Sample:::		
規格 ITEM	F9 SCRC 70B					
線組 WINDING	Φ0.5x0.5TSx100L(mm)		磁芯尺寸:			
測試頻率 TEST FREQ	Z1= 25MHZ	Z2= 100MHZ				
溫度 TEMP	℃	濕度 HUMIDITY	%			

項目 TEST ITEM	電氣性能 ELECTRIC CHARACTERISTICS				尺寸(單位:毫米) DIMENSION(unit:mm)							
	Z1(Ω)	Z2(Ω)	Z3(Ω)	Z4(Ω)	A	B	C	D	E	F	G	H
	75	130			16.5	14.0	7.0	30.0	2.5	13	23.0	7.0
+	/	/			1.0	1.0	0.8	1.0	1.0	0.5	0.6	0.5
-	0	0			1.0	1.0	0.8	1.0	1.0	0.5	0.6	0.5
1	81.8	154.8			16.50	14.40	6.92	30.08	2.15	13.01	23.11	6.92
2	81.6	155.6			16.40	14.30	6.95	30.06	2.21	13.10	23.20	6.95
3	82.0	155.0			16.39	14.31	6.90	30.07	2.27	13.06	23.16	6.90
4	82.3	155.3			16.37	14.33	6.93	30.20	2.13	13.12	23.15	6.93
5	82.4	154.4			16.45	14.35	6.92	30.14	2.14	13.06	23.14	6.92
6	81.2	154.2			16.43	14.37	6.99	30.12	2.10	12.95	23.09	6.99
7	81.0	155.0			16.48	14.39	7.01	30.27	2.05	12.99	23.00	7.01
8	82.2	155.2			16.36	14.32	7.08	30.29	2.09	12.94	22.95	7.08
9	82.5	154.5			16.54	14.34	7.04	30.32	2.12	12.89	22.99	7.04
10	81.2	154.2			16.52	14.36	7.07	30.18	2.28	12.98	22.99	7.07
$\bar{X}$	81.82	154.82			16.44	14.34	6.98	30.17	2.15	13.01	23.07	6.98
Y/N	Y	Y			Y	Y	Y	Y	Y	Y	Y	Y

測試儀器:  
TEST INSTRUMENTS:  
E4991A+16194A

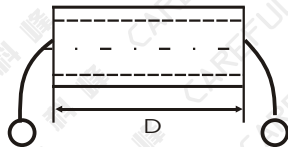

檢驗 INSPECTED	復核 CHECKED	確認 APPROVED
汪建琴	周紀君	沈學泉

A	首版First Edition	2022-12-14	Rosie
版本Rev.	變更內容說明Description of Change	日期Date	姓名Name

# 阻抗 - 頻率曲綫

## IMPEDANCE V.S FREQUENCY (Z-Y)

客戶名稱 CUSTOMER	LEPCOSLTD	日期 DATE	2022.12.14.
規格 ITEM	F9 SCRC 70B	編號 SERIAL NO.	KF 22121433473

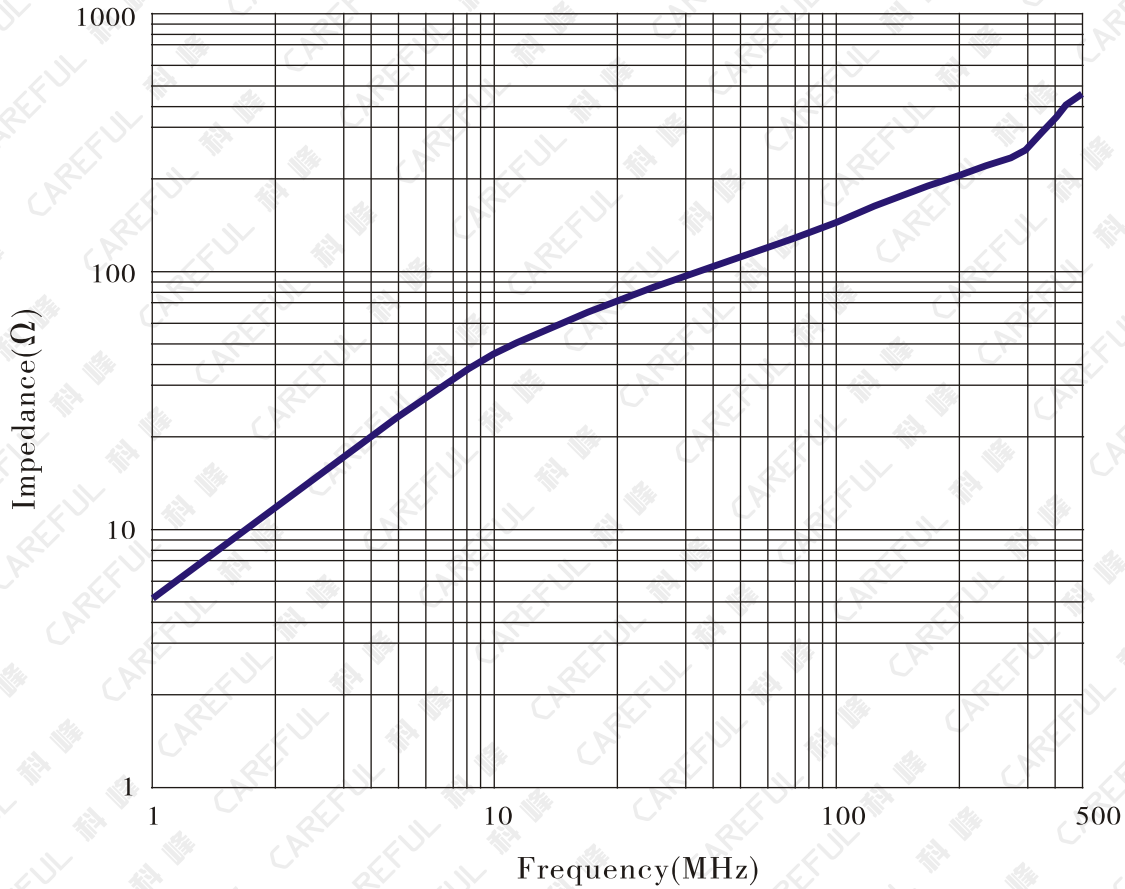

測試條件:  
TESTING CONDITION:

1. 測試儀器: E4991A+16194A  
Testing Equipment:
2. 測試頻率區間: 1-500MHz  
Testing Frequency Range:
3. 測試綫組: Φ0.5x0.5TSx100L(mm)  
Testing Coil Specification:

說明Note:  
本承認書在客戶收到7天之內, 須簽章返回, 逾期視為默認。  
The Specification Approval is required to be sent back to the supplier with customer's chop or signature on it within 4 days after receiving it, or we will take it as approved by customer automatically.

測試 TESTED	復核 CHECKED	確認 APPROVED
汪建琴	沈學泉	周紀君

A	首版First Edition	2022-12-14	Rosie
版本Rev.	變更內容說明Description of Change	日期Date	姓名Name